

Data Sheet for Piston Seal K17

Technical Data

Seal Materials	Max. Operating Temp °C	Pressure MPa	Glide Speed m/s
AR1+ ATL	100	50	0.5
AR2+ AF2	200	50	0.5

Media: Mineral oil-based hydraulic fluids.

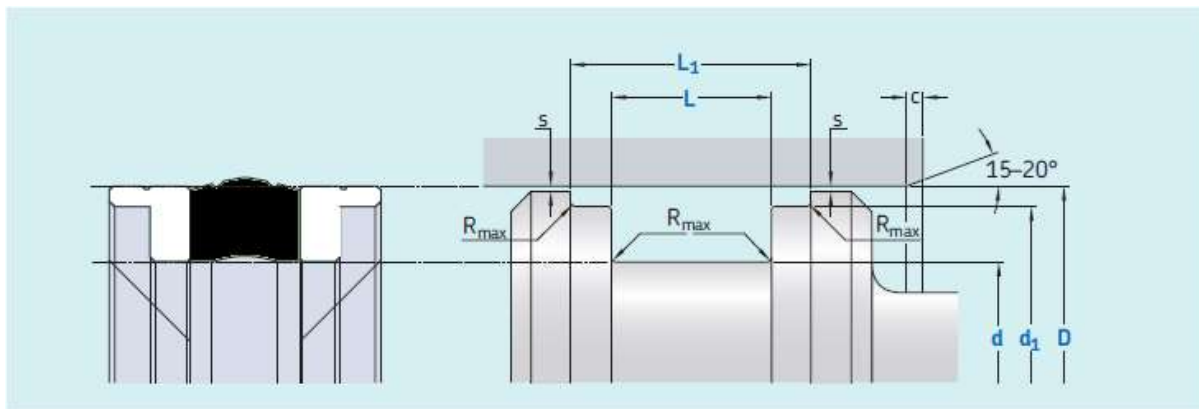

R_{max} : 0.3 mm

Bore Dia range D mm	Standard dimensions				Max. radial extrusion clearance S (400 Bars)
	Groove OD d mm	Diameter d_1 mm	Groove Length L mm	Total Length L_1 mm	
20-40	D-8	D-3	10	18	0.5
40-80	D-10	D-3	10	18	0.6
80-120	D-15	D-4	15	23	0.8
120-200	D-20	D-5	20	33	1
200-400	D-25	D-6	25	39	1

Note: For temp above 70°C extrusion clearance have to be lower

Ordering example: Piston Seal K17 85 x 100 / 96 15/23/ AR1+ATL