



Data Sheet for Piston Seal K05

Technical Data

Seal Materials	Max. Operating Temp °C	Pressure MPa	Glide Speed m/s
APU	100	2.5	0.5
AR1	100	2.5	0.5
AR2	200	2.5	0.5

Media: Air

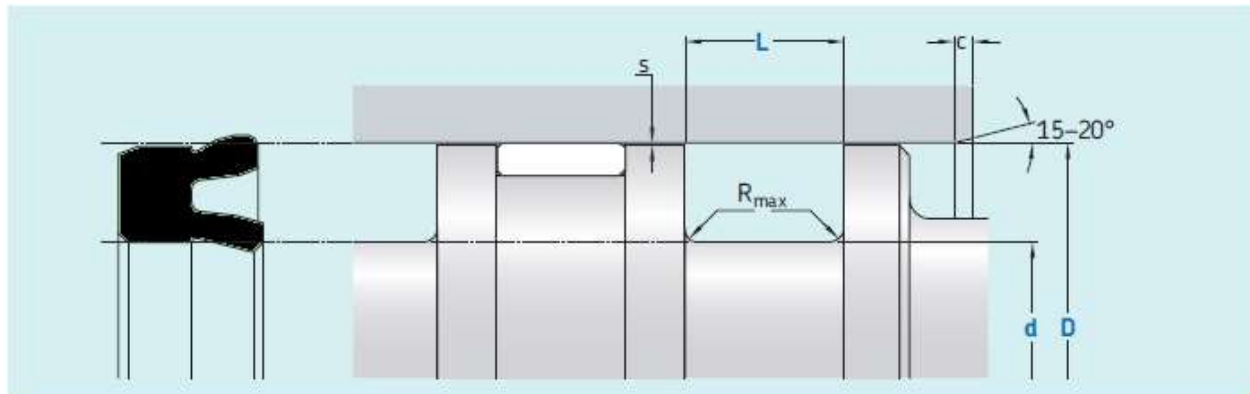

R_{max} : 0.4 mm

Standard dimensions			Max. radial extrusion clearance S mm	
Piston Dia range D mm	Groove OD d mm	Groove Length L mm	Pressure (Bars)	
10-25	D-8	6	25	0.35
25-50	D-10	7	25	0.4
50-75	D-12	8	25	0.5
75-150	D-15	10	25	0.6
150-300	D-20	12	25	0.7
300-500	D-25	18	25	0.8
			Note: For temp above 70°C extrusion clearance have to be lower	

Ordering example: Piston Seal K05 75 x 90 x 10 / AR1