

Data Sheet for Wiper Seal A11

Technical Data

Speed: Up to 0.5 m/s

Temperature: Use in mineral oils: -30°C to + 80°C

Media: Mineral oil-based hydraulic fluids.

Seal Materials: APU, AR1, AR2.

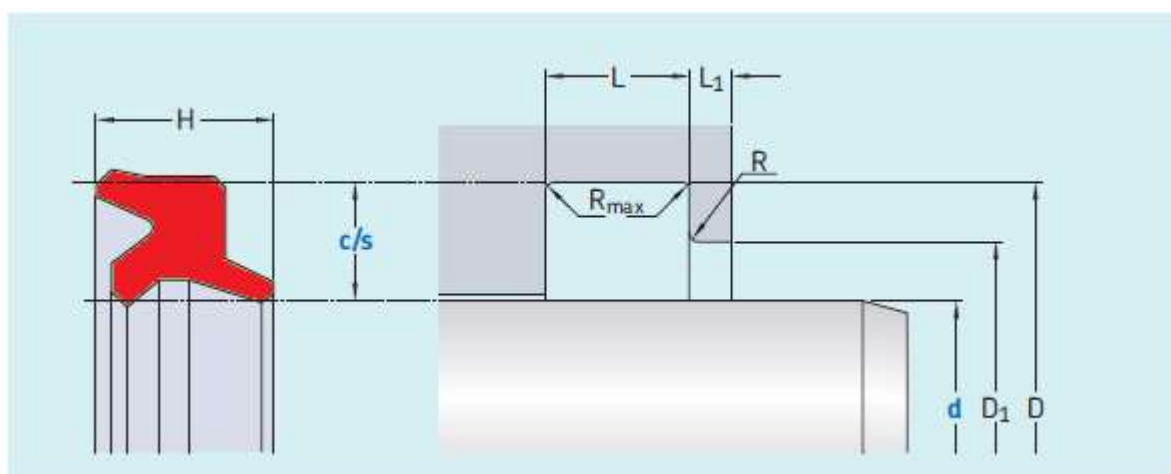

R_{max} : 0.4 mm

Rod Dia range d mm	Groove OD D mm	Neck Diameter D_1 mm	Groove Length L mm	Neck Length L_1 mm	Total Wiper Length H mm
10-30	$d+6$	$d+2.5$	4	2	4.8
30-55	$d+8$	$d+3$	5	2	6.5
56-110	$d+10$	$d+3$	6	2	7.5
>110	$d+15$	$d+4$	8.5	2	10.5

Ordering example: Wiper A11 90 x 100 x 6 /APU